

OPERATION MANUAL

FOR

5510 OSCILLOSCOPE

KIKUSUI ELECTRONICS CORP.

Power Requirements of this Product

Power requirements of this product have been changed and the relevant sections of the Operation Manual should be revised accordingly.

(Revision should be applied to items indicated by a check mark)

Input voltage

The input voltage of this product is _____ VAC,
and the voltage range is _____ to _____ VAC. Use the product within this range only.

Input fuse

The rating of this product's input fuse is _____ A, _____ VAC, and _____.

WARNING

- To avoid electrical shock, always disconnect the AC power cable or turn off the switch on the switchboard before attempting to check or replace the fuse.
- Use a fuse element having a shape, rating, and characteristics suitable for this product. The use of a fuse with a different rating or one that short circuits the fuse holder may result in fire, electric shock, or irreparable damage.

AC power cable

The product is provided with AC power cables described below. If the cable has no power plug, attach a power plug or crimp-style terminals to the cable in accordance with the wire colors specified in the drawing.

WARNING

- The attachment of a power plug or crimp-style terminals must be carried out by qualified personnel.

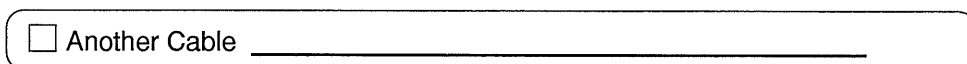
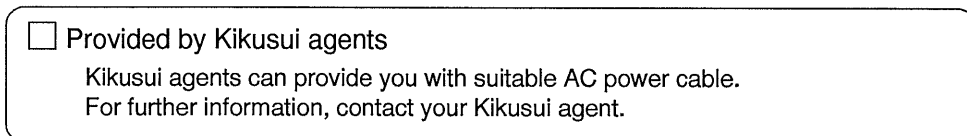
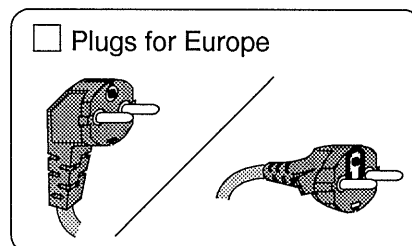
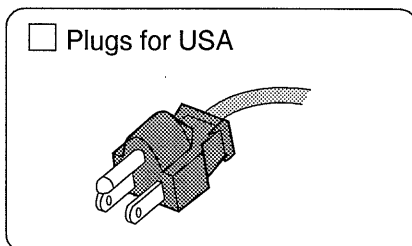
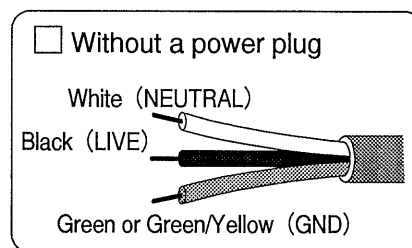
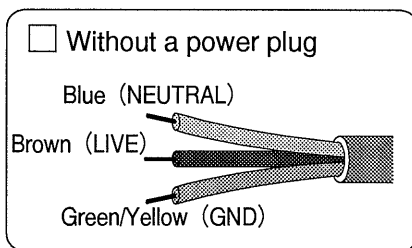

CONTENTS

	Page
1. GENERAL	1
2. SPECIFICATIONS	2
3. PRINCIPLE OF OPERATION	6
3.1 Front panel description	6
3.2 Description of parts on cabinet side face	11
3.3 Cautions regarding operation	14
3.4 Operation	15
4. MEASUREMENT	19
4.1 Connection of input signal	19
4.2 Voltage measurement	23
4.3 Time measurement	25
4.4 Frequency measurement	26
4.5 Phase difference measurement	28
4.6 TV signal observation	28
5. CALIBRATION	30
5.1 How to remove cover	30
5.2 Power supply	31
5.3 INTEN ADJ	31
5.4 CAL (calibration voltage)	31
5.5 Vertical axis deflection sensitivity	33
5.6 VOLTS/CM adjustment	33
5.7 TIME/CM adjustment	35
5.8 Sweep amplifier adjustment	36
5.9 Adjustment of STABILITY and vertical DC BAL	36

1. GENERAL

Model 5510 is a triggered type Oscilloscope designed compact and light weight using a 133mm Cathode-ray-tube.

The vertical system provides deflection factors from 10 mV/CM to 10 V/CM and a bandwidth of DC to 10 MHz. The horizontal deflection system provides calibrated sweep rates from $1\mu\text{S}/\text{CM}$ to $0.5\text{S}/\text{CM}$. Five times horizontal magnifier allows each sweep rate to be increased 5 times and provides a maximum sweep rate of $0.2\mu\text{S}/\text{CM}$ in the $1\mu\text{S}$ position. The ranges of TV.V and TV.H allow TV signal to be easily observed.

X-Y measurements can be made by applying the vertical (Y) signal to the vertical INPUT connector and the horizontal (X) signal to the EXT HOR OR TRIG IN terminal.

Using semiconductor elements in all circuits, Model 5510 minimizes drift and noise level and consumes little power.

Model 5510 also provides the terminals from which regulated 1 kHz square waves can be taken off to calibrate the sensitivity of the vertical axis and the probe.

Accessories

959M type probe	1
941B type terminal adaptor	1
Operation manual	1

2. SPECIFICATIONS

VERTICAL DEFLECTION SYSTEM

Deflection Factor Without probe	10 mV/CM to 10 V/CM in 10 steps. Steps in 1-2-5 sequence.
Accuracy of input attenuator	Within $\pm 3\%$
Uncalibrated (variable) range	Continuously variable between calibrated deflection factor settings. Extends maximum uncalibrated deflection factor to of least 2.5 V/CM.
Bandwidth with 4CM Reference	DC input coupling DC to 10 MHz or greater AC input coupling 2 Hz or less to 10 MHz or greater (-3dB points)
Rise time	Approx. 35 nS (calculated value)
Input impedance	1 M Ω $\pm 2\%$, with 38 pF ± 2 pF in parallel
Input terminal	Type UHF receptacle, type M male connector also applicable.
Maximum allowable input voltage	400 Vp-p at 10 mV/CM range and 600 Vp-p at other ranges Applied voltage is DC + ACp-p (AC: less than 1 kHz)

Input coupling modes AC and DC

Trace deviation by DC offset Within 2mm in 10 mV/CM
sensitivity

HORIZONTAL DEFLECTION SYSTEM

Sweep Rate Calibrated range Unmagnified 1 μ S/CM to 0.5S/CM, TV.H and TV.V. in 20 steps. Steps in 1-2-5 sequence.

Uncalibrated (variable) range Continuously variable between calibrated sweep rate settings. Extends slowest uncalibrated sweep rate to at least 1.25 S/CM.

Sweep time accuracy Unmagnified Within $\pm 5\%$ of indicated sweep rate. (Line Voltage; within $\pm 10\%$)

Sweep magnifier 5 times

Magnification accuracy $\pm 5\%$

Trace shift by magnification on horizontal axis Within 10mm at center of screen

TRIGGERING

Trigger signal source INT: internal, EXT: external
INT includes TV.V and TV.H

Trigger Coupling AC

Trigger Slope Sweep can be triggered from the positive-going or negative-going portion of trigger signal.

Internal trigger sensitivity	Within 50 Hz to 5 MHz: 10mm amplitude on screen
	Within 20 Hz to 10 MHz: 20mm amplitude on screen
External trigger sensitivity	Within 50 Hz to 5 MHz: 1 V _{p-p}
	Within 20 Hz to 10 MHz: 2 V _{p-p}
AUTO (auto-sweeping)	Rated trigger sensitivity is satisfied with respect to more than 50 Hz
Triggering mode	Trigger sweep and auto-sweep
External trigger input impedance	Approx. 100 K Ω with less than 50pF in parallel.
Maximum allowable input voltage	100 V _{p-p} , where voltage is DC + AC _{p-p} and AC is at less than 1 kHz.
Input terminal	Binding post (also used for external sweep)

EXTERNAL HORIZONTAL INPUT

Sensitivity	More than 1.5 V/CM (more than 300 mV/CM; magnified 5 times)
Continuous sensitivity variation	Capable of attenuating down to approx. 1/10.
Bandwidth	DC to 200 kHz or greater at -3dB points (Continuous variable sensitivity attenuator set to maximum.)

Input impedance	Approx. 220 K Ω with 50pF in parallel
Maximum allowable input voltage	100 Vp-p, where voltage is DC + ACp-p and AC is at less than 1 kHz.
Input terminal	Binding post (also used for external trigger)

CALIBRATION VOLTAGE

Waveform	Square wave
Polarity	Positive-going with base line at 0V
Output voltage	Two regulated voltages of 50mVp-p and 500 mVp-p
Repetition Rate	Approx. 1 kHz
Output voltage accuracy	Within $\pm 3\%$

CATHODE-RAY TUBE

Name of model	133mm, circular type
Acceleration voltage	Approx. 1600V
Effective area	10cm (horizontal) x 8cm (vertical)

POWER SUPP

Voltage	----- V $\pm 10\%$
Frequency	50 to 60 Hz
Power consumption	Approx. 25 VA

MECHANISM

Dimensions	260 H x 175 W x 460 Dmm (maximum)
	235 H x 165 W x 400 Dmm (cabinet only)

Weight Approx. 6.8kg

ACCESSORIES

959 M type probe	1
941 B type terminal adaptor	1
Operation manual	1

3. OPERATION

3.1 Description of parts on front panel

INTEN	Knob for adjusting intensity of CRT. It also serves as a power switch.
POWER OFF	When this knob is set to POWER OFF, power is switched off.
FOCUS	Knob for adjusting so that the spot or trace on the CRT screen becomes clear.
CALIBRATOR	Output terminal of square wave generator for calibrating the sensitivity of the vertical axis and the probe.

Vertical deflection section

INPUT	Input terminal for vertical axis. It is the UHF type receptacle, to which input
-------	--

signal or the probe is connected.

GND

Ground terminal connected with cabinet and panel

AC DC GND

Switch for selectively setting input coupling. When the GND button is pushed, the input terminal is separated from the vertical amplifier, and the input of the vertical amplifier is grounded. The DC button allows the DC coupling mode, and input signal is observed including the DC component. In this case, the position of the trace in the GND mode is 0V. The AC button allows the input terminal of the vertical amplifier to be AC-coupled, and the AC component only is observed with the DC component cut off.

VOLTS/CM

Switch for changing over vertical deflection sensitivity within 10 mV/CM to 10 V/CM in ten steps. An indication value in each range shows voltage per 1 cm vertical amplitude on the screen with the VARIABLE knob turned fully clockwise to the CAL'D position.

VARIABLE

Knob for attenuating input signal continuously. Extreme counterclockwise position allows less than 1/2.5 the level at the CAL'D position. Therefore, in each interrange of VOLTS/CM, the input level can be continuously varied.

POSITION

Knob for shifting vertical position of trace to a position allowing easy measurement.

Horizontal deflection section

TIME/CM

Switch for changing over sweep time within 1 μ S/CM to 0.5 S/CM including TV.H, TV.V and EXT HOR in 21-step. Each indication value in a range of 1 μ S/CM to 0.5 S/CM is sweep time per 1cm on the screen with VARIABLE turned fully clockwise to the CAL'D position. The TV.H and TV.V positions allow two cycles of TV video signals to be displayed.

EXT HOR

When the TIME/CM switch is set to EXT HOR, internal sweeping stops and the external sweep state is brought about. The spot deflects in the horizontal direction in proportion to voltage applied

to the EXT HOR OR TRIG IN input terminal (red binding post).

VARIABLE

Knob for varying sweep time continuously during internal sweeping. Extreme counterclockwise position allows less than 1/2.5 the sweep time in the CAL'D position. Therefore, sweep time in each interranging can be continuously varied. The lowest speed is less than 1.25 sec/CM. During external sweeping, this serves as an attenuator for horizontal input signal applied to the EXT HOR OR TRIG IN input terminal. The CAL'D position allows the maximum deflection sensitivity (more than 1.5 V/CM), and in the extreme counterclockwise position, sensitivity is reduced down to about one tenth. (Deflection sensitivity can be boosted five times further by pulling the horizontal POSITION knob; more than 300 mV/CM.)

TRIGGERING LEVEL

Knob for selecting sweep time and adjusting trigger level. The AUTO position

allows autosweeping, and sweeping is kept with no signal applied. Whenever input signal of more than 50 Hz is applied, sweeping synchronizes with it.

When the knob is turned clockwise from the AUTO position, the trigger sweep state is brought about, and the spot is ready at the left edge of the screen with on input signal. Whenever input signal is applied, the oscilloscope starts sweeping. A sweep starting point on input waveform can be selected by adjusting the knob.

SOURCE

Switch for selectively setting type of trigger signal.

When the INT switch is pushed, waveform displayed on the screen is used as a trigger signal source.

When the EXT switch is pushed, the external signal applied to the EXT HOR OR TRIG IN input terminal is used as a trigger signal.

SLOPE

Switch for selectively setting slope of sweep starting point of trigger signal

waveform. When the + button is pushed, triggering is conducted with the ascending slope of waveform. Pushing the - button permits triggering with the descending slope.

EXT HOR OR TRIG IN During internal sweep, this is used as an input terminal for external trigger signal. During external sweep, it is used as a horizontal axis input terminal, DC-coupled to the horizontal amplifier.

POSITION Knob for shifting horizontal position of spot or trace.

PULL 5 x MAG Sweep can be magnified five times by pulling the POSITION knob.

3.2 Description of parts on cabinet side face

The cabinet is provided with three adjusting holes for semi-fixed resistors on the left side face and with one hole on the right side face. These holes allow adjustment with a screw-driver.

Left side face

DC BAL Semi-fixed resistor for adjusting DC balance of vertical axis. Adjust this

GAIN CAL

until the trace does not deviate up and down by turning the VARIABLE knob. Semi-fixed resistor for calibrating vertical axis sensitivity. Calibration is conducted by using the output voltage from the CALIBRATOR terminal.

ASTIG

Semi-fixed resistor for adjusting together with the FOCUS knob so that the spot or trace becomes sharp on the screen.

Right side face

STABILITY

Semi-fixed resistor for adjusting stability of horizontal sweep generator. Once it is adjusted, there is little fluctuation. However, if horizontal sweeping fluctuates due to variation in the ambient temperature, readjust this resistor as follows;

1. Push the GND button with no input signal applied.
2. Turn the TRIGGERING LEVEL knob fully clockwise (opposite side of AUTO).
3. Set the TIME/CM switch to 1mS.
4. Set the SOURCE switch to INT.
5. Turn the STABILITY resistor fully

counterclockwise, and the free running state is brought about. The free running is the state where the sweep generator operates automatically for sweeping. Unlike auto-sweep, synchronization cannot then be attained, and the trace remains bright even if sweep speed increases.

6. Next, slowly turn the STABILITY resistor clockwise, and the free running stops. This point is the optimum point of stability.
7. Check synchronization by means of a sinewave signal generator within 50 Hz to 10 MHz. (The CALIBRATOR signal of Model 5510 may be used instead of that signal generator.) Set the TRIGGERING LEVEL knob to AUTO. Connect the output of the generator to the vertical axis INPUT terminal. Set amplitude on the screen to approx. 2cm, using three frequencies of 50 Hz, 10 kHz and 10 MHz. Check the

synchronization when the TIME/CM or VARIABLE knob is changed. If the waveform is doubled, turn the STABILITY resistor slightly clockwise.

However, be careful not to turn it too far. Otherwise, synchronization may not be attained at 10 MHz, even if it is attained at 50 Hz and 10 kHz.

3.3 Precaution

Primary supply voltage

Model 5510 operates safely within a primary supply voltage range of $\text{---V} \pm 10\%$. Since an input voltage above this range causes trouble, maintain that range by suitable means.

Fuse

Model 5510 uses a time lag fuse of 0.5A. Be sure to use the same type fuse for replacement.

Ambient temperature

Model 5510 operates properly within an ambient temperature range of 0 to $+40^{\circ}\text{C}$. To satisfy the specifications sufficiently, a range of $+10$ to $+35^{\circ}\text{C}$ is recommended.

Withstand voltage of each input terminal

For each input terminal and accessory probe, the maximum allowable input voltages are specified as follows;

Vertical axis input terminal 400 Vp-p in 0.01 V/CM position
of VOLTS/CM

600 Vp-p in ranges other than
0.01 V/CM

Accessory probe 600 Vp-p

EXT HOR OR TRIG IN terminal 100 Vp-p

Brightness of CRT

Avoid increasing brightness of CRT too much. Also avoid leaving the spot for a long time as it is.

Otherwise, the phosphor of CRT may be burnt.

3.4 Operation

Before switching on power, set each knob on the front panel as follows;

INTENSITY	POWER OFF position
FOCUS	Center
VERTICAL POSITION	Center
HORIZONTAL POSITION	Center
TIME/CM	1 mS/CM
TRIGGERING LEVEL	AUTO position

Plug the power cord into a _____V AC socket. Turn the INTENSITY knob fully clockwise. About ten seconds later, the bright trace appears on the screen. Turn the INTENSITY

knob counterclockwise until optimum brightness is obtained.

Next, turn the FOCUS knob until the trace is clear.

Feed Model 5510's calibration signal to the vertical axis input terminal, and the waveform will appear on the screen.

In this case, use the 50 mV calibration voltage, and set each switch and knob as follows;

AC DC GND	DC
VOLTS/CM	0.01 V/CM
VARIABLE	CAL'D
TIME/CM	1 mS/CM
VARIABLE	CAL'D
TRIGGERING LEVEL	AUTO
SOURCE	INT
SLOPE	+

The above-shown setting permits observing a square wave of 5 cm vertical amplitude.

As the VOLTS/CM switch is changed over counterclockwise, vertical amplitude attenuates step by step. Also counterclockwise turning the VARIABLE knob attenuates amplitude continuously. As described above, input signal can be optionally adjusted by means of the VOLTS/CM switch and VARIABLE knob.

Time base and triggering

Since the calibration voltage is 1 kHz square wave, with the TIME/CM knob in the 1 mS range, one cycle of square waves can be displayed in about 1 cm length horizontally.

As the TIME/CM switch is changed over clockwise step by step, the sweep time of the time base becomes shorter. Also, the sweep time can be varied continuously by means of the VARIABLE knob. Therefore, part of square wave as well as the entire wave of calibration voltage can be measured.

Namely, when the TIME/CM knob is switched clockwise, the leading edge of square wave is magnified as shown in Fig. 3-1.

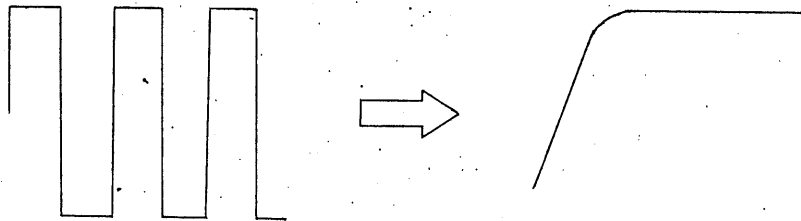

Variation of waveform on screen
by switching sweep time

Fig. 3 - 1

To measure variation of triggering points, while referring to Fig. 3-2, first, push the + button of SLOPE and then push the -button.

Also, turn the LEVEL knob.

By turning the LEVEL knob, let sweeping start from the desired point on the leading or tailing edge of square wave.

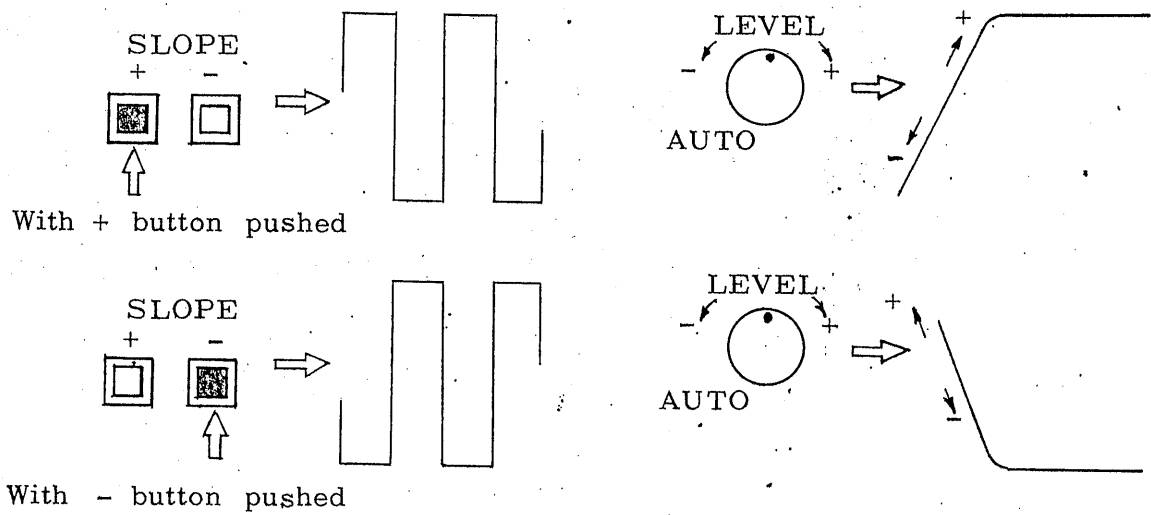

SLOPE selection and waveform on screen

Turning direction of LEVEL knob and variation in triggering point on waveform

Fig. 3 - 2

Triggering signal source

To hold input signal waveform on the screen, it is necessary to feed the input signal waveform or signal having a constant timing with the input signal to the trigger circuit of the time base.

Internal trigger

When the TRIGGERING SOURCE switch's INT button is pushed,

input signal is amplified by the vertical axis amplifier up to a suitable level, and is fed to the trigger circuit. Therefore, very stable synchronization is attained and operation is also easy. This is called the internal trigger.

External trigger

When the TRIGGERING SOURCE switch's EXT button is pushed, the input of the trigger circuit is connected to the EXT HOR OR TRIG IN terminal, through which external trigger signal is fed to the trigger circuit. This is called the external trigger. The external trigger actuates the trigger circuit, unaffected by the vertical deflection system.

Therefore, this is effective to measure the waveform of ripples superimposed on HF signal or irregularly changing pulses which do not allow easy synchronizing.

4. MEASUREMENT

4.1 Connection of input signal

Model 5510's input impedance as viewed from the vertical input terminal side is $1\text{ M}\Omega$ with 38 pF in parallel. When the accessory probe is used, it is $10\text{ M}\Omega$ with less than 14 pF in parallel.

There are various methods for connecting Model 5510 with a signal source to be measured, such as use of ordinary rubber-covered wire, shielded wire, coaxial cable and the probe.

These methods should be selected according to the following given conditions;

Level of output impedance of input signal source

Input signal level and frequency

Induction from outside

Distance between input signal source and oscilloscope

Table 4-1 shows connection methods classified according to the type of input signal.

Table 4 - 1

Type of input signal	Connection method		Rubber-covered wire	Shielded wire	Probe	Coaxial cable	Misc.
	Impedance	Distance					
LF	Low impedance	Near	○	○	○	○	
		Far		○		○	
	High impedance	Near		○	○		
		Far		○			
HF	Low impedance	Near			○	○	
		Far				○	
	High impedance	Near			○		
		Far					

Method with rubber-covered wire

Attach the M type accessory terminal adapter to the input terminal of the vertical axis. Connect rubber-covered wire to this adapter. This method is simple and has an advantage that

there is not attenuation of input signal.

However, if rubber-covered wire is long or the output impedance of the input signal source is high, this method is affected by induction from the outside, resulting in incorrect measurement.

Since its stray capacity with respect to the ground is also large, the circuit to be measured is affected considerably as compared with measurement with the accessory probe of 10:1 in attenuation ratio.

Method with shielded wire

Use of shielded wire avoids induction from the outside. However, since the capacitance of shielded wire is considerably high, (50 to 100 pF/m), this method is unsuitable for the input signal source of high output impedance or for high frequency signal source.

Method with probe

Use the accessory probe of 10:1 in attenuation ratio. As shown Fig. 4-1, since its lead itself is shielded, and attenuating resistor R_p and its parallel capacitance C_p compose a wide band attenuator, this is suitable for the input signal source with high output impedance or of high frequency.

Input impedance with probe used

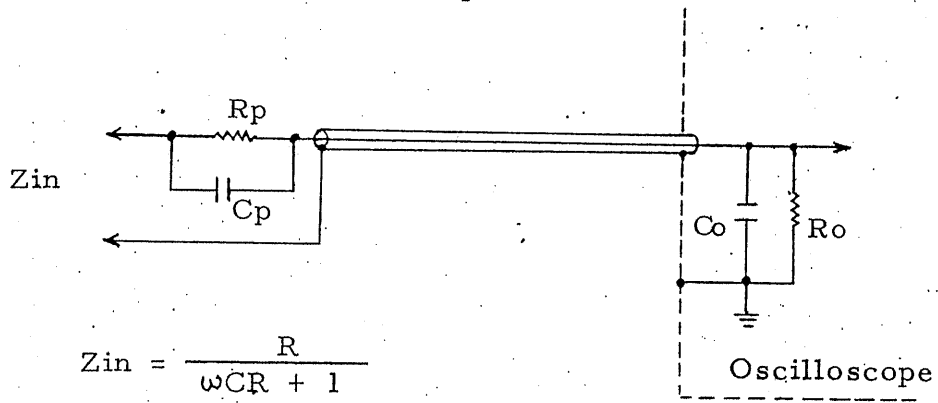

$$Z_{in} = \frac{R}{\omega CR + 1}$$

$$R = R_p + R_o$$

$$C = \frac{C_p \times C_o}{C_p + C_o}$$

$$C_p = \frac{C_o \times R_o}{R_p}$$

(Co includes cable capacitance.)

Fig. 4 - 1

Method with coaxial cable

When the output impedance of the input signal source is 50Ω or 75Ω , etc., use coaxial cable having a corresponding impedance and let both impedances match. The output signal from the circuit to be measured can then be transmitted without attenuating over a high frequency range. As shown in Fig. 4-2, perform impedance matching on the oscilloscope side.

Circuit to be measured

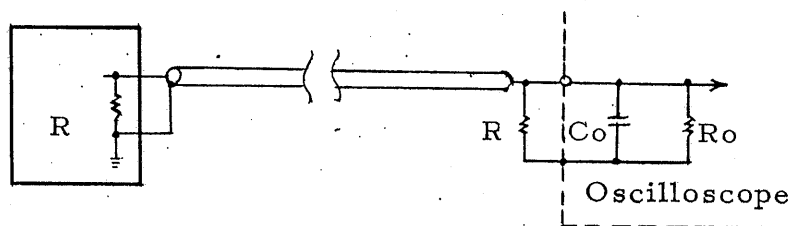

Fig. 4 - 2

4.2 Voltage measurement

DC voltage measurement

Set the time base to the auto-sweep mode. Set the TIME/CM switch to 1 mS/CM and display the sweep line on the screen. Next, set the AC DC GND switch of the vertical axis to GND. Since the vertical position of the sweep line then is the 0V level of the vertical input as shown in Fig. 4-3, set it to a position allowing easy measurement on the screen.

Then, change over the AC DC GND switch to DC. Feed the voltage of the point to be measured to the vertical axis input, and read with the scale on the screen how much the sweep line deviates.

If the sweep line is spread out of the screen, switch the VOLTS/CM knob counterclockwise until the sweep line is shifted to a position allowing easy measurement. When the shifted sweep line is positioned on the upper side of the first position, the input voltage is in positive polarity. If it is positioned on the lower side, the input is negative.

The input voltage can be found by applying vertical amplitude (cm) measured by means of the scale on the screen to formulas (4-1) and (4-2).

With probe of 10:1 in attenuation ratio used

$$\text{Voltage } V = \text{Indication value of VOLTS/CM} \times \text{Amplitude}$$

$$\times 10 \quad \text{----- (4-1)}$$

Without probe

$$\text{Voltage } V = \text{Indication value of VOLT/CM} \times \text{Amplitude}$$

$$\text{----- (4-2)}$$

AC voltage measurement

As shown in Fig. 4-3, when AC voltage is superimposed on DC voltage, with the AC DC GND Switch set to DC, the sweep line is spread out of the screen by the DC voltage, if it is higher than the AC voltage. Thus, the AC voltage component cannot be measured.

In such cases, the AC voltage component can be restored into the screen by the vertical POSITION knob. However, this method cannot be recommended since it results in a measurement error. Also, although the AC voltage component can be restored in the screen by changing over the VOLTS/CM switch, amplitude becomes smaller, causing the input voltage not to be measured. In such cases, set the AC DC GND switch to AC. The capacitor is then connected in series with the vertical input, and the DC voltage is cut off. Therefore, the AC voltage component only can be magnified enough to be measured.

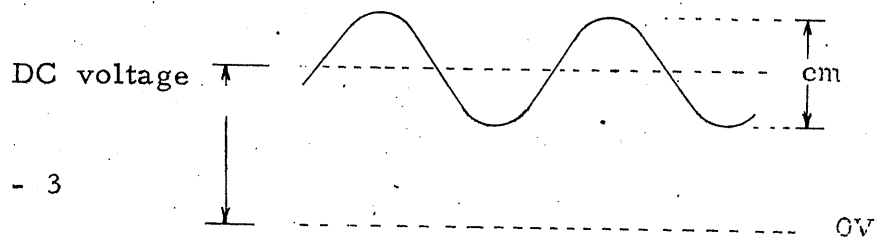

Fig. 4 - 3

The input voltage can then be calculated by applying amplitude(cm) to formulas (4-1) and (4-2).

(Measurement in the AC position results in 3dB attenuation in a low frequency range less than 2 Hz).

The AC voltage calculated from formulas (4-1) and (4-2) is a peak value (Vp-p). The effective value (Vrms) of sinewave is found from the following formula (4-3).

$$\text{Voltage (Vrms)} = \frac{\text{Voltage (Vp-p)}}{2 \sqrt{2}} \quad \text{----- (4-3)}$$

4.3 Time measurement

Time interval measurement

To measure time interval between two optional points on the waveform, set the VARIABLE knob for TIME/CM to CAL'D. The time interval will then be directly shown with an indication value on TIME/CM.

First, set the TRIGGERING LEVEL knob to AUTO.

Next, change over the TIME/CM switch until the interval between two points on the waveform can be easily measured.

$$\text{Time T(sec)} = \text{TIME/CM(sec)} \times \text{Length on screen (cm)} \quad \text{----- (4-4)}$$

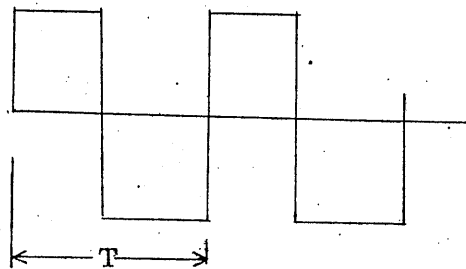

Fig. 4 - 4

4.4 Frequency measurement

There are three frequency measuring methods.

The first is the method that time per one cycle is found from formula (4-4) and frequency is calculated with the following formula (4-5).

$$\text{Frequency (Hz)} = \frac{1}{\text{Period T(sec)}} \quad \text{----- (4-5)}$$

In the second method, time per several ten cycles (10 to 20 cycles) is found. Namely, count the number N of cycles contained within 10 cm divisions on the horizontal scale, and find frequency by applying N to the following formula (4-6);

$$\text{Frequency (Hz)} = \frac{N}{\text{Value of TIME/CM(sec)} \times 10} \quad \text{----- (4-6)}$$

This method enables measurement error to be smaller than in the first method by making N large.

The above-mentioned two are methods that frequency is found by measuring time. With simple waveform such as sine wave in a frequency range less than 5 kHz, frequency can be measured by displaying Lissajous figure in the XY scope mode. To set the XY scope, change over the TIME/CM switch to EXT HOR. Feed unknown signal and given signal to the vertical axis INPUT terminal and the EXT HOR OR TRIG IN terminal respectively. Adjust the VOLTS/CM switch and HOR VARIABLE knob until both vertical and horizontal amplitudes

become 4 cm.

Next, vary the frequency of the given signal until the Lissajous' figure of 1:1 shown Fig. 4-5 is displayed.

The Lissajous' figure of 1:1 in frequency ratio is one of a circle, ellipse or linear line. When frequency ratio is around 1:1, the figure varies continuously and repeatedly from (1) to (5). As frequency ratio becomes closer to 1:1, motion is slow. When both frequencies coincide completely, the figure becomes still in either shape. The unknown frequency then is equal to the given frequency.

With various frequency ratio, unknown frequency can be found from the figure. However, it is easiest and most accurate to use the figure of 1:1 in frequency ratio by means of a signal generator which allows a wide range of frequencies to be varied continuously.

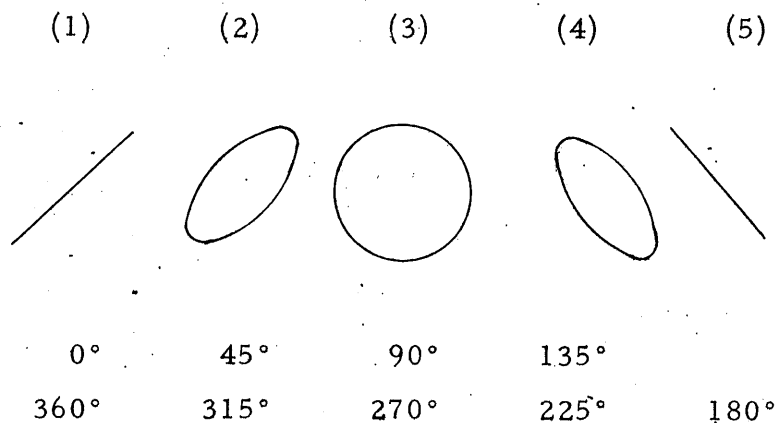

Fig. 4 - 5

4.5 Phase difference measurement

Measurement by means of Lissajous' figure (between two signals having the same frequency)

As stated in the frequency measurement item above, display the Lissajous' figure on the screen in the XY scope.

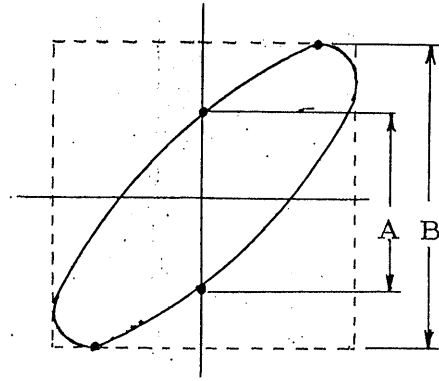

Fig: 4 - 6

In Fig. 4-6, angular phase difference is obtained from the following formula;

$$\sin \theta = \frac{A}{B} \quad \text{----- (4-7)}$$

Caution: Since in a high frequency range, the phase difference of Model 5510 itself causes an error, operate Model 5510 below 5 kHz. (The phase difference of Model 5510 itself is less than 3° below 5 kHz. However, since it is below 3° at 20 kHz with the VARIABLE knob for controlling the horizontal axis sensitivity set to CAL'D, a working range will be expanded.)

4.6 TV signal observation

To observe composite video signal, set the TIME/CM switch

to the TV.H or TV.V range. The synchronizing separator circuit is energized, and the video signal can be easily observed.

When the sync signal is negative as shown Fig.4-7, push the - SLOPE button. When positive, push the + SLOPE button. Stable synchronization is attained. When the VARIABLE knob is set to CAL'D, two cycles of horizontal or vertical video signals appear on the screen in the TV.H or TV.V position respectively.

Other signal in every TV circuit than composite video signal, if it has a constant repetition rate, can be easily synchronized in TV.H and TV.V ranges.

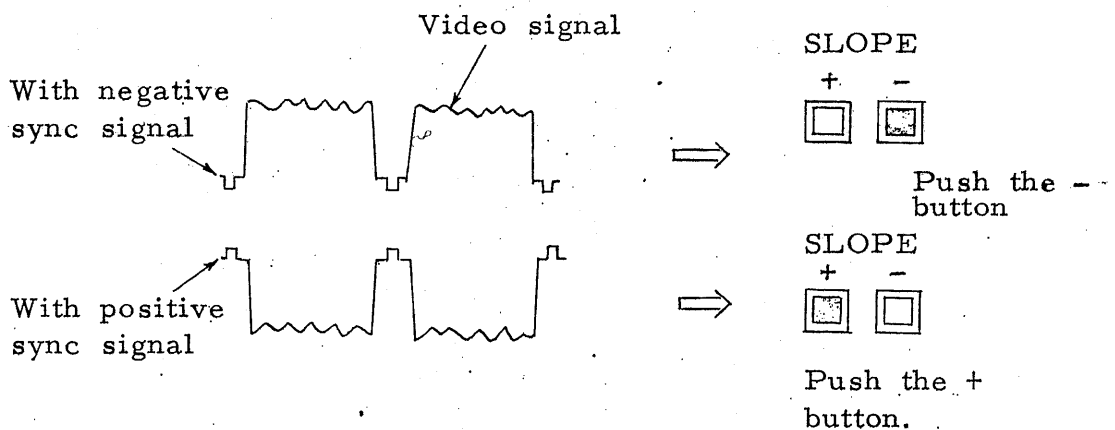

Fig. 4 - 7

5 CALIBRATION

After using Model 5510 for a some term, be sure to calibrate it. During repair of precise parts. calibration is also necessary.

5.1 How to remove covers

Almost all adjustment parts requiring calibration are located inside the cabinet. As shown in Fig. 5-1, remove the top cover plate and bottom plate prior to calibration. Remove eight screws from the top cover plate and four screws from the bottom plate, which are shown with the arrow mark.

During calibration, be sure to maintain the AC power supply at.....V.

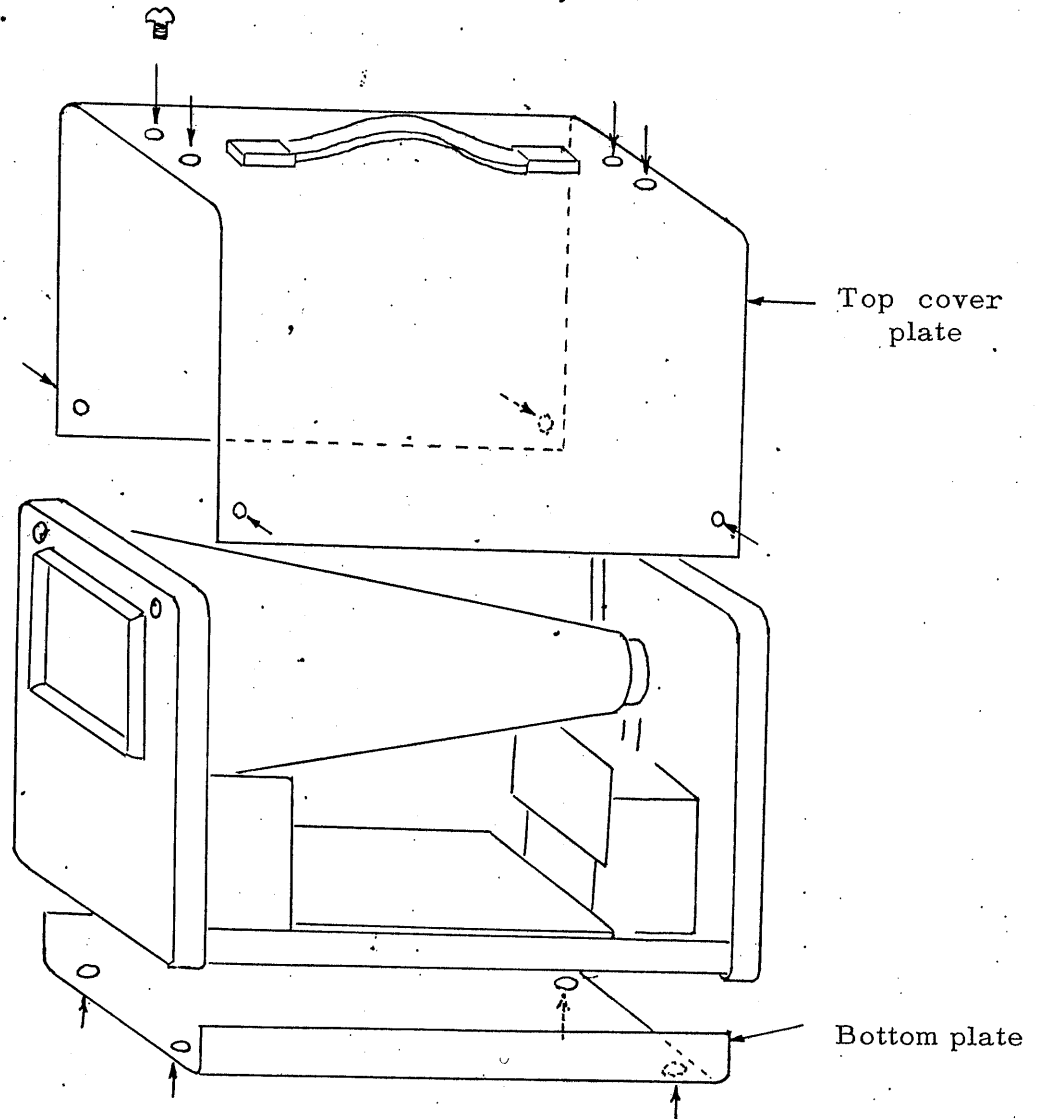

Fig. 5-1

5.2 Power supply

Fig. 5-2 shows the power supply system of Model 5510.

In this system, regulated +15V and -15V require calibration.

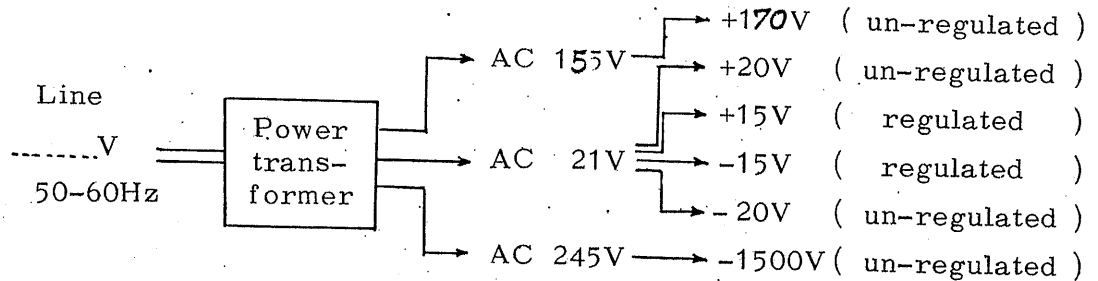

Fig. 5 - 2

First, adjust R116 (Fig.5-4) for -15V with a screw-driver.

Next, turn R110 until +15V is obtained.

Since turning R116 (-15V) causes +15V to be changed, be sure to start with -15V adjustment.

5.3 INTEN ADJ

Semi-fixed resistor for adjusting a variation range of INTENSITY (Fig.5-4, R145). Adjust it so that the trace disappears when the INTENSITY knob on the panel is set to about 45 rightward.

5.4 CAL (calibration voltage)

Semi-fixed resistor for adjusting output voltage at CALIBRATOR terminal (Fig.5-5, R809). When the test point (Fig.5-5, T.P.)

is connected to the chassis or the GND terminal, 1 kHz generator stops, and DC voltage only is obtained at the CALIBRATOR output terminal. Adjust R809 for 500mV by means of an accurate voltmeter, and 50 mV adjustment is also automatically attained.

Next, disconnect the test point from the GND terminal, and the square waves of 500 mVp-p and 50 mVp-p are obtained at the CARIBRATOR output voltage terminal respectively

(Fig. 5-3).

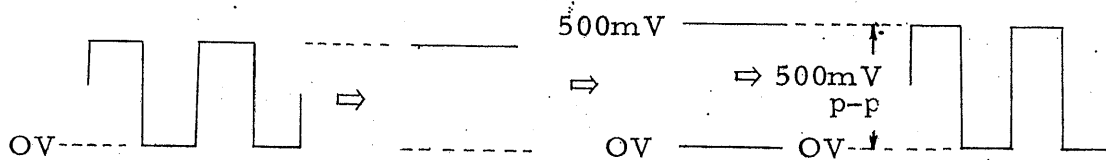

Connect the test point to the GND terminal to obtain DC voltage.

Set the DC voltage to 500 mV.

Disconnect the test point from the GND terminal, and 500 mVp-p square wave is obtained.

Fig. 5 - 3

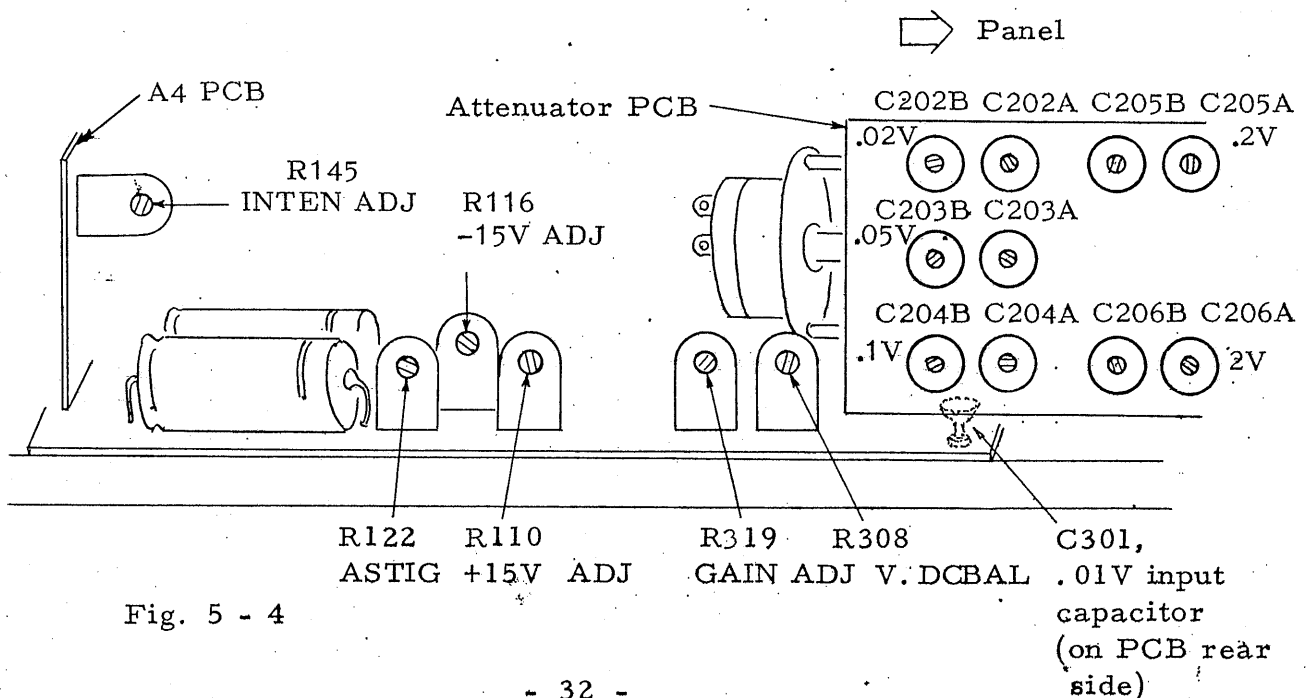

Fig. 5 - 4

-Panel

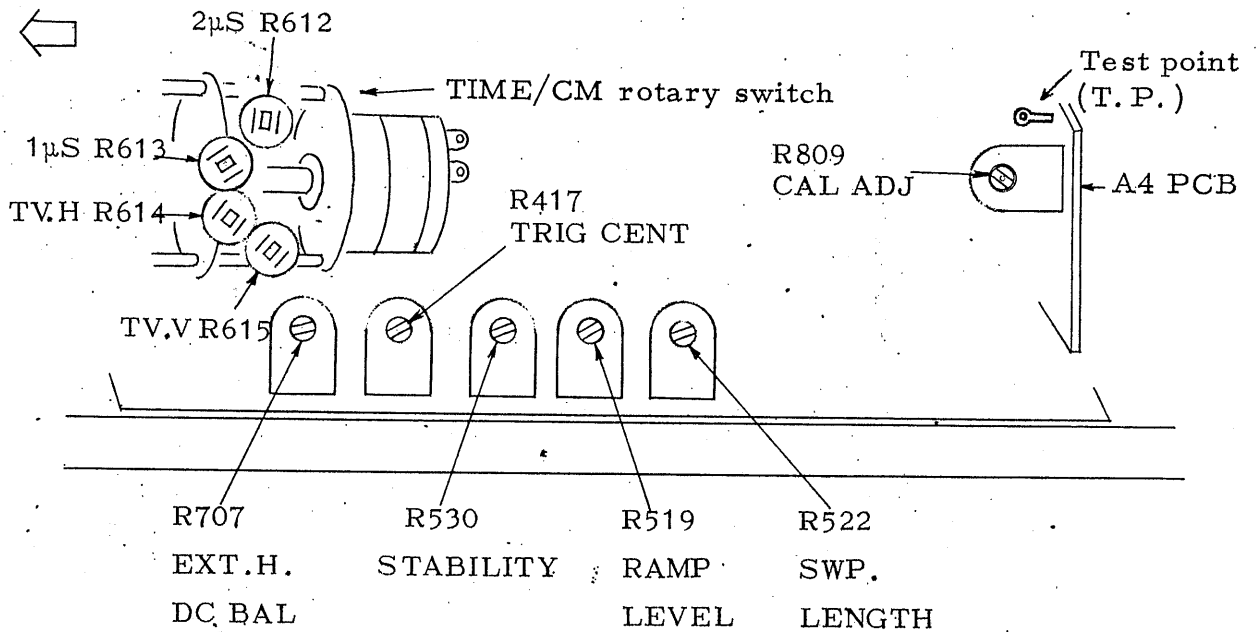

Fig. 5 - 5

5.5 Vertical axis deflection sensitivity

- (1) Set the VOLTS/CM switch to 0.01V.
- (2) Set the VARIABLE knob to CAL'D.
- (3) Feed a 1kHz square wave of 50 mVp-p (or calibrated signal from CALIBRATOR terminal) to the vertical input terminal.
- (4) Adjust R319 (Fig. 5-4) so that vertical amplitude is 5 cm.

5.6 VOLTS/CM switch adjustment

For this switch, adjust input capacitance and phase characteristic simultaneously by turning the trimmer capacitor on the attenuator PCB (Fig.5-4) by means of a screwdriver.

- (1) Connect a capacity meter allowing 40pF measurement to the vertical axis input terminal (Kikusui's 231A LC meter recommended).
- (2) Set the VOLTS/CM switch to 0.01. Adjust C301 so that input capacitance in this range is 38pF.
- (3) Feed 1 kHz square wave having less than 0.1 μ S rise time to the vertical input terminal.
- (4) Set the VOLTS/CM switch to 0.02V. Perform phase adjustment by turning C202B until the upper portion of the square wave is level (Fig. 5-6).
- (5) As with (4) above, adjust phase in the 0.05V and 0.1V ranges by turning C203B and C204B respectively.
- (6) Connect the capacity meter to the vertical input terminal again. Adjust input capacitance in the 0.02, 0.05 and 0.1V ranges for 38 pF by turning C202A, C203A and C204A respectively.
- (7) As with (4) above, perform phase adjustment in the 0.2 and 2V ranges by turning C205B and C206B respectively.
- (8) As with (6) above, turn C205A and C206A until input capacitance is 38 pF in the 0.2 and 2V ranges respectively.
- (9) Recheck the procedures of (1) through (8).
- (10) The other ranges are automatically adjusted through the procedures of (1) through (8).

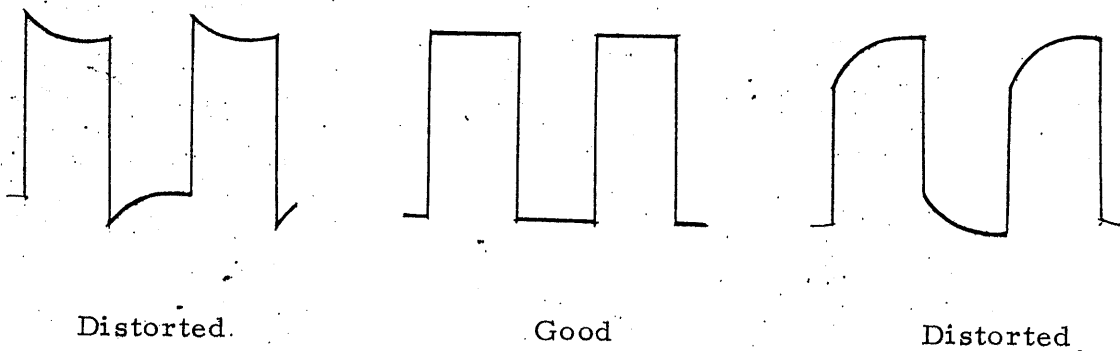

Fig. 5 - 6

5.7 TIME/CM adjustment

- (1) Connect a time maker generator to the vertical input terminal.
- (2) Set the VARIABLE knob to CAL'D.
- (3) Set the TIME/CM switch to 1mS. Make marker signal conform with the scale divisions by turning semi-fixed resistor R723(Fig.5-7), and the ranges of 0.5S to 5 μ S are automatically adjusted.
- (4) As with (3) above, adjust the 2 μ S and 1 μ S ranges by turning semi-fixed resistors R612 and R613 on the TIME/CM rotary switch (Fig.5-5).
- (5) Adjust the TV.H and TV.V ranges by turning R614 and R615 on the TIME/CM rotary switch until two cycles of vertical and horizontal video signal waveforms appear on the screen respectively.

- (6) Reset the TIME/CM switch to 1mS. Adjust MAG ADJ semi-fixed resistor R724 (Fig.5-7) so that magnification becomes five times when sweep is magnified by pulling the HORIZONTAL POSITION knob.
- (7) Adjust MAG REGIS semi-fixed resistor R733 until the trace located at the center of the screen does not deviate due to magnified sweeping.
- (8) Recheck the procedures of (1) through (7).

5.8 Sweep amplitude adjustment

Adjust SWP LENGTH semi-fixed resistor R522(Fig.5-5) so that amplitude of the trace is 10.5cm in the 1mS range.

For sweep amplitude, strict adjustment is not always necessary. However, if there is excessive deviation, stable operation cannot be obtained. Rechecking is advisable.

5.9 STABILITY and vertical DC BAL

For adjustment of the STABILITY and vertical DC BAL semi-fixed resistors, refer to Para. 3.2 (description of parts on cabinet side face). These can be adjusted from the outside of the cabinet.

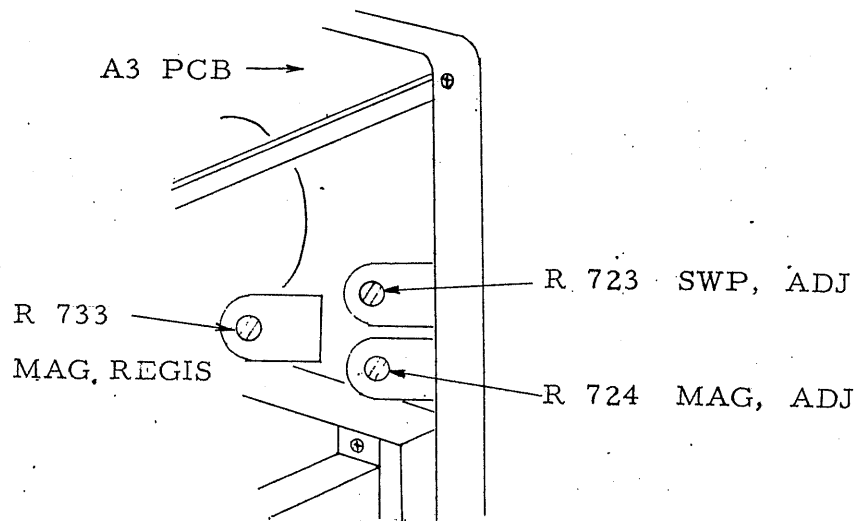
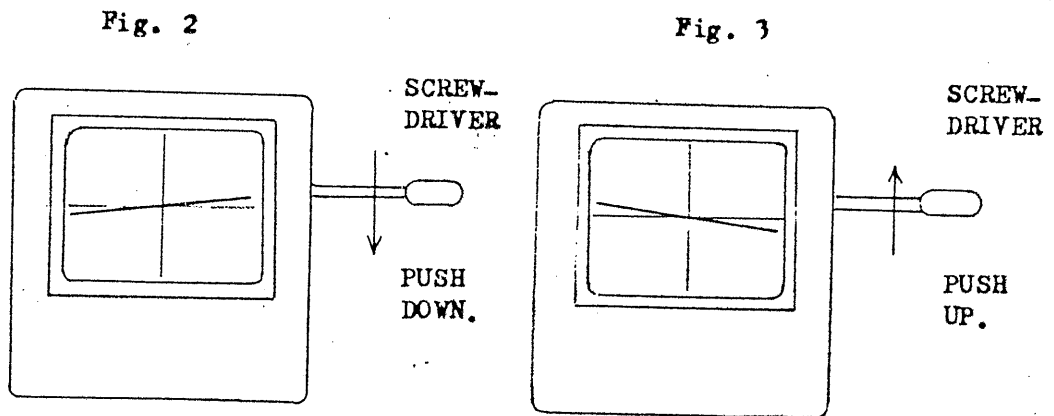

Fig. 5 - 7

ADJUSTING PROCEDURE

1. With a screwdriver (+), rotate the 4-mm screw counterclockwise for approximately 3 turns to loosen it. Note that the screw will come off if it is turned further.
2. When the screw is loosened, it can be moved upward and downward and in response the CRT is slightly rotated and thus the horizontal trace angle is adjustable. This adjustment should be made under the state that the power of the oscilloscope is turned on and it is displaying its horizontal trace.



3. Fig. 2 illustrates the case the right-hand side of the trace is high. In this case, set the screwdriver to the 4-mm screw and move it downward so that the trace is made parallel with the graticule. The 4-mm screw is heavy and should be pushed downward strongly.
4. Fig. 3 illustrates the case the left-hand side of the trace is high. In this case, move the 4-mm screw upward.
5. When the trace is made parallel with the graticule, lock tightly the 4-mm screw by turning it clockwise (LOCK) with the screwdriver.

The adjustment is complete by the above procedure.